

Distributed By:
Metal Finishing Supply Co., Inc.
PO Box 526 - Brookfield, WI 53008-0526
(262) 782-0555 Fax: (262) 782-8888
www.metalfinishingsupply.biz

Zero Pulsar



Packed With Features

- Filter cartridge is automatically cleaned each time the pedal is operated.
- Pull-through exhaust fan reduces wear on impeller blades.
- Unique Air Logic System maximizes air flow to the blast nozzle.
- Door safety interlocks interrupt blasting if either door is opened.
- Tough, full-length gloves protect the operator's hands and arms.
- Large window and top-mounted light allow clear view of work.
- Blow-off gun clears away dust and media after blasting.
- Rubberized wear-plate prolongs reclaimer life.

SIMPLE

Each Pulsar® component has been engineered to work in balance with the whole system. Capacities for the sump, reclaimer, dust collector, and blast system are perfectly matched. Because the components are housed in one cabinet, routing of hoses and tubes is simple and direct. The result is a cabinet that's easy to install, easy to use, and easy to maintain.

TOUGH

We build Pulsar® cabinets to stand up to years of heavy industrial use. The blast enclosure and support structure are made from 14-gauge and heavier steel. Formed-in-place stress members prevent cabinet warping and buckling.

QUIET

The double-wall, sound-insulated doors and the door frame, form an edge baffle and positive seal to prevent the escape of dust and abrasive.



The top-mounted light module features an abrasive-resistant Lexan® cover and twin fluorescent bulbs



The tilt-out frame makes changing the tempered-glass window a snap.



An independently adjustable pulse regulator maximizes cartridge-cleaning effectiveness and minimizes noise.



Lift-off hinges let you remove and replace the door in seconds, without tools.

ACCESSIBLE

Side access allows easy adjustment and maintenance. Emptying the dust drum or replacing the filter cartridge takes just minutes. Side access puts the reclaimer door, the metering valve, the moisture separator, and the pulse pressure regulator with gauge at your fingertips. On the Pulsar® pressure cabinets, you can reach the pressure vessel's hand hole and metering valve from the side.

SMART

Pulsar® controls are conveniently located within the operator's reach. The operator can easily adjust air pressure while blasting to suit the application.

The cabinet-top-mounted light module creates full-view, uniform lighting inside the cabinet, and is easily serviced.

Tilt-out window allows tool-free window replacement in minutes.

Positive latches pull the doors closed tight.

Lift-off hinges allow you to swap the standard door for a pass-through door, a vestibule door, or a door fitted with our standard tumble basket.

(All are available through Clemco's Options Plus program)



SELF-CLEANING

Each time the pedal is pressed or released, a pulse of compressed air knocks caked-on dust off the cartridge and into the dust drum. The dust collector cartridge traps more than 99.7 percent of the dust particles down to 0.5 micron. If cabinet visibility decreases, a few press-and-release cycles quickly clean the filter cartridge.

The long-lasting cartridge can be replaced in minutes, reducing down-time.

Pulsar's pulse valve has its own pressure regulator and gauge.

VERSATILE

All Pulsars come equipped to handle most common recycleable blast media, from glass bead to coarse aluminum oxide. To convey heavy steel media more efficiently, an optional steel media kit is available for use with Pulsar VI and III-P and VI-P models.

The kit includes reduced-ID recovery hoses to increase the media velocity, allowing more thorough separation of dust and debris in the reclaimer.

Another feature exclusive to Pulsar pressure cabinets is a special metering valve with urethane-coated metering plate that lets the valve handle super-fine media.

The Heart of the Pulsar® System

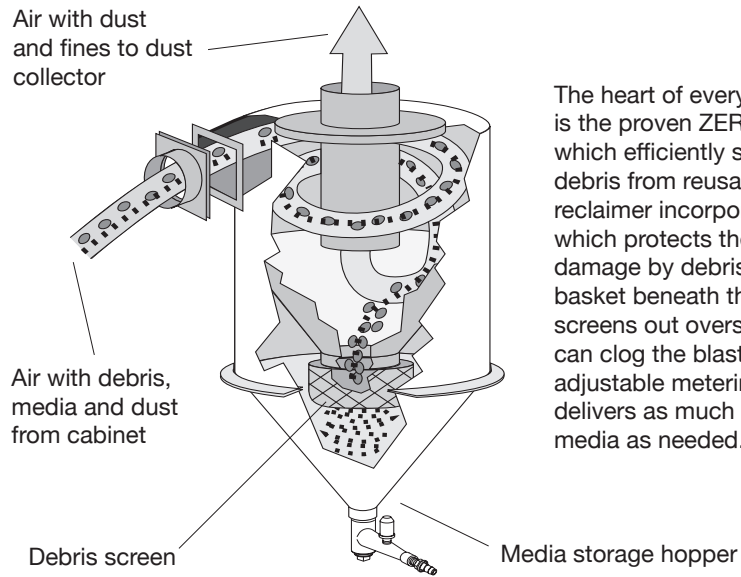

The heart of every Pulsar® cabinet is the proven ZERO reclaimer—which efficiently separates dust and debris from reusable media. The reclaimer incorporates a wear-plate which protects the inlet from damage by debris. The large basket beneath the reclaimer screens out oversize material that can clog the blast system. A fully adjustable metering system delivers as much or as little media as needed.

A Simple Balanced System

Reclaimer (1) separates reusable media from dust and broken media. Dirty air flows into dust collector (2), passes through the replaceable cartridge (3), which traps the contaminants. Clean air is exhausted into the enclosure above the reclaimer, (4).

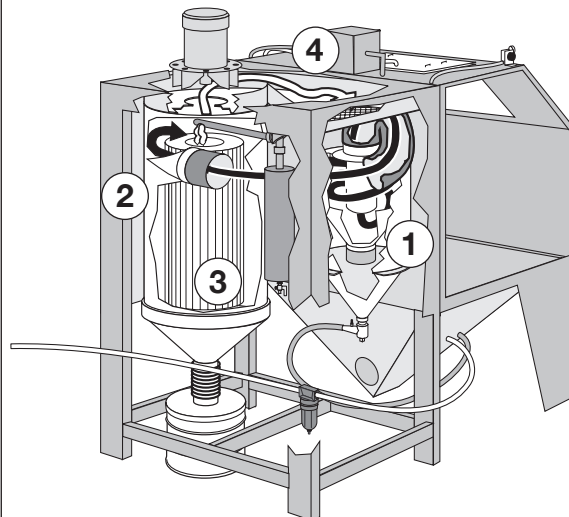

Pulsar® pressure cabinets

Suction

In the pressure system a 1 cu ft blast machine (5) replaces the media storage hopper. The blast machine is automatically refilled from the reclaimer (1) each time the foot pedal is released.

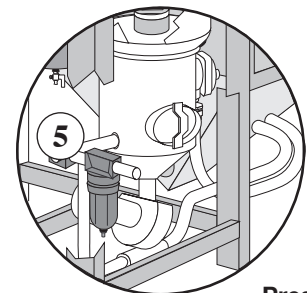

Pressure

Pulsar® III & Pulsar® VI Suction Cabinets

- Continuous reclamation and high-production blasting.
- Simple media metering system allows precise adjustment.
- Exclusive BNP Blast Gun sets the industry standard for performance and durability.
- Number 5 Gun and ceramic nozzle standard.
- Easy access to reclaimer door for adding fresh media, and to dust drum for dust removal.
- Efficient 1/2-inch air filter traps oil and water that can ruin blast media and contaminate cleaned parts.
- Pulsar® VI features flanged mounting on reclaimer that can accept suction or pressure blast system.



BNP GUN

The ZERO BNP gun sets the industry's standard for delivering the most cleaning power. The comfortable pistol-grip design reduces operator fatigue and increases productivity during prolonged blasting.

Optional tungsten carbide and boron carbide nozzles easily handle aggressive media.

CONVERTIBLE

Pulsar® cabinets are built with flexibility in mind. When your production needs change, your Pulsar® VI can be converted from suction blast to pressure blast.



Pulsar® III-PE

Ergonomic configuration allows sit-down operation; available in Pulsar III and VI models.

APPLICATIONS

- Remove rust, millscale, heat scale, and carbon build-up
- Strip paint, powder coating, plating and anodizing
- Eliminate burrs, parting lines, and flashings
- Extract residual sand from castings
- Beautify steel, stainless steel, aluminum, brass and other metals
- Etch artwork and lettering into glass, stone, plastics and metal
- Clean residue and release agents from molds



The Pulsar® suction blast cabinets combine blast, recovery, reclaim and dust collection in an efficient, compact enclosure.

Pulsar® VI-P Pressure Cabinet

- 1-cu-ft blast machine (with automatic refill from reclaimer) holds enough media to blast continuously for up to 30 minutes.
- ASME-code blast machine rated for 125 psi with large hand hole for internal maintenance and 35-degree conical bottom for smooth media flow.
- Standard Number 3 tungsten carbide nozzle delivers hundreds of hours of efficient blasting with most abrasives. Pulsar® VI-P accepts nozzles up to Number 5.
- Efficient 1-inch air filter delivers high-volume air and traps oil and water that can ruin blast media and contaminate cleaned parts.
- Pulsar VI-P features flanged mounting on reclaimer to accept suction or pressure blast system.

FAST CLEANING

The Pulsar® VI-P incorporates a 1 cubic foot capacity blast machine in place of the suction blast system found on the Pulsar® VI.

Pressure blasting cleans at rates three to four times faster than suction blasting and results in a better profile for bonding coatings or for stress relief on metals.

CONVERTIBLE

Pulsar® cabinets are built with flexibility in mind. When your production needs change, your Pulsar® VI-P can be converted from pressure blast to suction blast.



Pulsar® VI-P

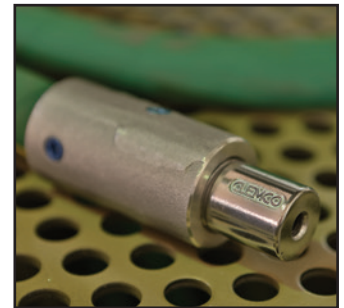

TUNGSTEN CARBIDE NOZZLE

A Number 3 tungsten carbide blast nozzle comes standard on the Pulsar® VI-P.

An optional boron carbide nozzle handles super-aggressive abrasives.



Flange-mounted blast machine on Pulsar® VIP

S P E C I F I C A T I O N S

Complete System

Actual space requirements depend on desired work flow.
 Allow additional work space for operator and maintenance.

Pulsar® III

- A.** 62" (1575 mm)
- B.** 38" (965 mm)
- C.** 76" (1930 mm)

Pulsar® VI

- A.** 71" (1803 mm)
- B.** 52" (1321 mm)
- C.** 84" (2134 mm)

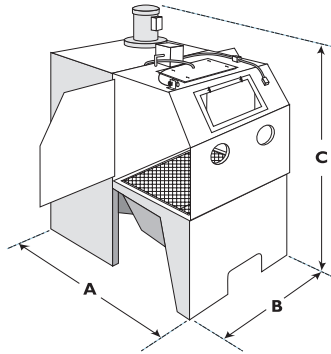

Cabinet: Working Chamber Size

- | | |
|--------------------------------------|--------------------------------------|
| Pulsar® III: 36" wide (914mm) | Pulsar® VI: 50" wide (1270mm) |
| 35" deep (889mm) | 39" deep (991mm) |
| 37" high (940mm) | 43" high (1092mm) |

Cabinet: Door Opening

Pulsar® III:

- A.** 32.5" (826 mm)
- B.** 34" (864 mm)
- C.** 19" (483 mm)
- D.** 17.5" (445 mm)
- E.** 24" (610 mm)

Pulsar® VI:

- A.** 36.5" (927 mm)
- B.** 38" (965 mm)
- C.** 19.5" (495 mm)
- D.** 20.5" (521 mm)
- E.** 27" (686 mm)

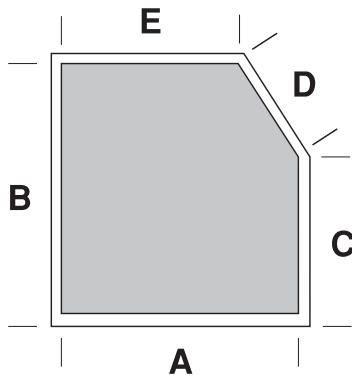

Electrical

- Pulsar® III:** 1/2HP, 115V, 1PH, 60HZ, (.37KW, 220V, 1PH, 50HZ)
- Pulsar® VI:** 1HP, 115V, 1PH, 60HZ, (.75KW, 220V, 1PH, 50HZ)

Some installations may require electrical connection by a qualified electrician.

Window Size (safety glass)

- 19.5" wide (495 mm)
- 12.5" high (318 mm)

Filtering Area

- Pulsar® III** 107 ft² (9,9 m²) • **Pulsar® VI** 195 ft² (18,1 m²)

Dust concentration in exhausted air is nominally 5.0 mg/m³.
 For especially dust sensitive work environments, order the optional HEPA filter.

Guns/Nozzles: Suction Blast Air Requirements

Noz.	Nozzle Ori.	Air Jet	CFM@80psi	M ³ /Min@5,5 Bar
No. 4	5/16"	1/8"	21	0,6
No. 5	5/16"	5/32"	32	0,9
No. 6	3/8"	3/16"	48	1,35
No. 7	7/16"	7/32"	62	1,75
No. 8	1/2"	1/4"	85	2,4

Pulsar® III and Pulsar® VI cabinets are furnished with a No. 5 gun and ceramic nozzle.

Guns/Nozzles: Pressure Blast Air Requirements

Noz.	Nozzle Ori.	CFM@80psi	M ³ /Min@5,5 Bar	CFM@100psi	M ³ /Min@7 Bar
No. 2	1/8"	17	0,5	20	0,6
No. 3	3/16"	38	1,08	45	1,3
No. 4	1/4"	68	1,93	81	2,3
No. 5	5/16"	113	3,20	137	4,0

Pulsar® VI-P cabinets are furnished with a No. 3 tungsten carbide nozzle.

Reclaimer Flow Rate

- Pulsar® III:** Nominal 300 cfm • **Pulsar® VI:** Nominal 600 cfm

Dust Collector

Reverse-pulse cartridge dust collectors (which trap 99.7% of dust down to 0.5 micron) allow non-stop, high-production blasting. The polyester-cellulose cartridges are pulse cleaned each time the foot pedal is pressed and released for maximum filter efficiency. A dust collector auto-pulse kit is available as an option. Worn cartridges can be replaced in minutes.

Ordering Information

Model	Standard	Ergo	Weight
Suction Cabinets			
Pulsar® III (300)	20185	24747	850
Pulsar® III-S (600)	25157		850
Pulsar® VI (600)	20190	25019	1150
Pressure Cabinets			
Pulsar III-P (300)	24746	24745	1260
Pulsar VI-P (600)	21639	24853	1550

Popular Accessories

- Adjustable Gun Mount
- Oscillator Assembly
- Alox Kit
- Pass-through doors
- Air-powered Vertical Lift Door
- Steel Grit/Shot Media Kit
- Dust Collector Auto-pulse Kit
- Timed Door Release
- Curtains
- 20-, 24-, and 30-inch Turntables
- HEPA filter
- Two Gallon Tumble Basket
- Manometer Kit
- Work Car & Track Assembly



ISO 9001 certified. Clemco is committed to continuous product improvement. Specifications are subject to change without notice.
 ©2015 Clemco Industries Corp. • One Cable Car Drive • Washington, MO 63090 • Phone: 636.239.4300 • Fax: 800.726.7559